

made in stainless steel AISI 304 - AISI 316 upon request

Floor drains with square top plate and vertical outlet removable Total Hygienic cup shaped odor trap and filter basket.

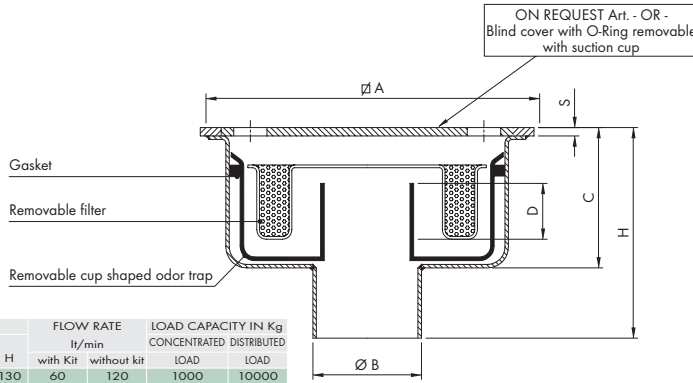

Article	DIMENSION in mm						FLOW RATE		LOAD CAPACITY IN Kg	
	S	Ø A	Ø B	C	D	H	with Kit	without kit	LOAD CONCENTRATED	LOAD DISTRIBUTED
R-ribassato										
R 75 V 206 TH	6	200	75*	70	20	130	60	120	1000	10000
75 V 206 TH	6	200	75*	110	50	170	60	120	1000	10000
R 110 V 206 TH	6	200	110*	70	20	130	60	120	1000	10000
110 V 206 TH	6	200	110*	110	50	170	60	120	1000	10000
R 75 V 308 TH	8	300	75*	70	20	130	80	180	1000	10000
75 V 308 TH	8	300	75*	110	50	170	80	180	1000	10000
R 110 V 308 TH	8	300	110*	70	20	130	135	340	1000	10000
110 V 308 TH	8	300	110*	110	50	170	135	340	1000	10000

Dwg. N° 0115

* Different outlet diameters on request.

N.B.: A depth water seal (dimension D) of 50 mm is in compliance with standard UNI EN 1253-1

Floor drains with square top plate and horizontal outlet removable Total Hygienic cup shaped odor trap and filter basket.

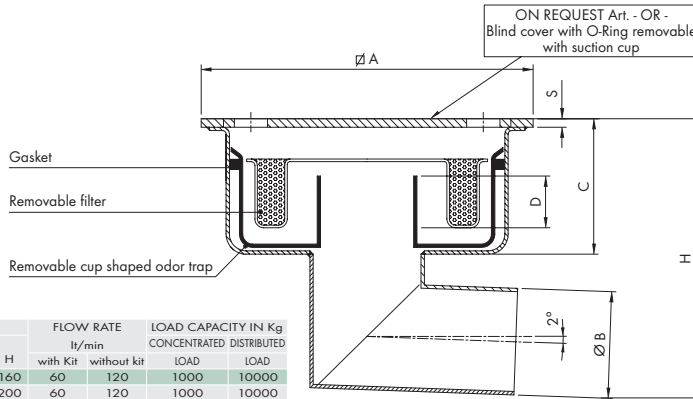

Article	DIMENSION in mm						FLOW RATE		LOAD CAPACITY IN Kg	
	S	Ø A	Ø B	C	D	H	with Kit	without kit	LOAD CONCENTRATED	LOAD DISTRIBUTED
R-ribassato										
R 75 L 206 TH	6	200	75*	70	20	160	60	120	1000	10000
75 L 206 TH	6	200	75*	110	50	200	60	120	1000	10000
R 110 L 206 TH	6	200	110*	70	20	195	60	120	1000	10000
110 L 206 TH	6	200	110*	110	50	235	60	120	1000	10000
R 75 L 308 TH	8	300	75*	70	20	160	80	180	1000	10000
75 L 308 TH	8	300	75*	110	50	200	80	180	1000	10000
R 110 L 308 TH	8	300	110*	70	20	195	135	340	1000	10000
110 L 308 TH	8	300	110*	110	50	235	135	340	1000	10000

Dwg. N° 0012

* Different outlet diameters on request (different overall installation height).

N.B.: A depth water seal (dimension D) of 50 mm is in compliance with standard UNI EN 1253-1

Ultra-low profile floor drains with horizontal outlet removable Total Hygienic cup shaped odor trap.

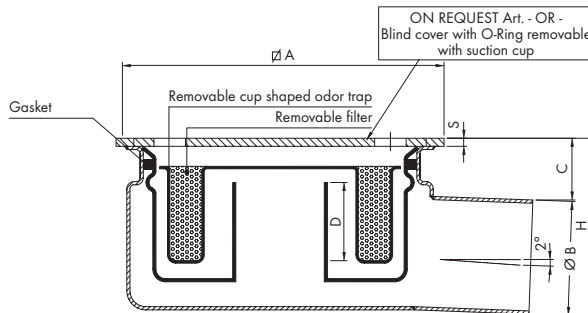

Article	DIMENSION in mm						FLOW RATE		LOAD CAPACITY IN Kg	
	S	Ø A	Ø B	C	D	H	with Kit	without kit	LOAD CONCENTRATED	LOAD DISTRIBUTED
UR 50 L 206 TH	6	200	50*	30	20	80	50	80	1000	10000
UR 63 L 206 TH	6	200	63*	32	20	95	60	120	1000	10000
UR 75 L 206 TH	6	200	75*	35	50	125	60	120	1000	10000
UR 110 L 206 TH	6	200	110*	40	50	155	60	120	1000	10000
UR 50 L 308 TH	8	300	50*	30	20	80	50	100	1000	10000
UR 63 L 308 TH	8	300	63*	32	20	95	60	140	1000	10000
UR 75 L 308 TH	8	300	75*	35	50	125	80	180	1000	10000
UR 110 L 308 TH	8	300	110*	40	50	155	135	340	1000	10000

Dwg. N° 0002

* Different outlet diameters on request.

N.B.: A depth water seal (dimension D) of 50 mm is in compliance with standard UNI EN 1253-1

The removable cup shaped odor trap makes it possible to empty the wastewater out of the floor drain. It is highly recommended to fill the floor drain with water after cleaning in order to stop smells from coming back up.